

GreaseShield®

The Grease Management Solution

The World's Best and Only Eco Certified Grease Recovery Unit



GS1850-PF

APPLICATIONS



POTWASH SINKS



DOUBLE BOWL SINKS



PRE-RINSE SINKS



HOOD DISHWASHERS



COMBI OVENS

ENVIRONMENTAL BENEFITS

- ✓ **Protects the Environment** - from pollution caused by Fats, Oils and Grease (FOGs)
- ✓ **Eco-Friendly** - GreaseShield® uses the least amount of energy in its class.
- ✓ **Protects the Drainage Network** - allowing drain lines to flow free from FOGs
- ✓ **Harvests a source of Renewable Energy**
- ✓ **Compliance with local water companies and landlords** - preventing prosecution.

OPERATIONAL & COST SAVING BENEFITS

- ✓ **Eliminates recurring drain blockages** - caused by FOGs.
- ✓ **Eliminates frequent pumping costs and grease trap emptying**
- ✓ **No requirement to purchase enzymes or bio additives**
- ✓ **Automatic Grease Separation** - including emulsified animal fat.
- ✓ **No heating element** - so no risk of fire.
- ✓ **User Friendliness** - No need for staff to access the internal of the machine and no more foul smelling grease traps.
- ✓ **No silt valve** - Therefore preventing the discharge of FOGs to the drain line.



Environmental
Products and Services Ltd

Award Winning Technology

www.GreaseShield.com

sales@epas-ltd.com

HEAD OFFICE - +44 (0) 28 3083 3081

GB OFFICE - +44 (0) 161 477 5555

GreaseShield®

The Grease Management Solution

The World's Best and Only Eco Certified Grease Recovery Unit

GS1850-PF - DAILY MAINTENANCE

No need to access the inside of the GreaseShield® - FOG's are automatically separated and extracted from your kitchen's waste water.



Empty and clean the FOG Collection Container daily - The FOG's are collected in the external container.

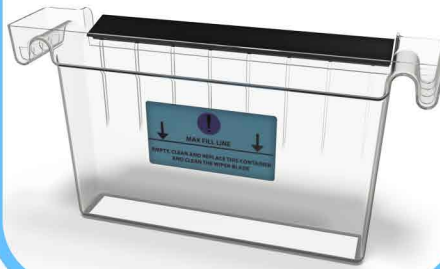

Empty and clean the PreFilter Basket Daily - Solids and food waste are collected in the interchangeable PreFilter Basket.

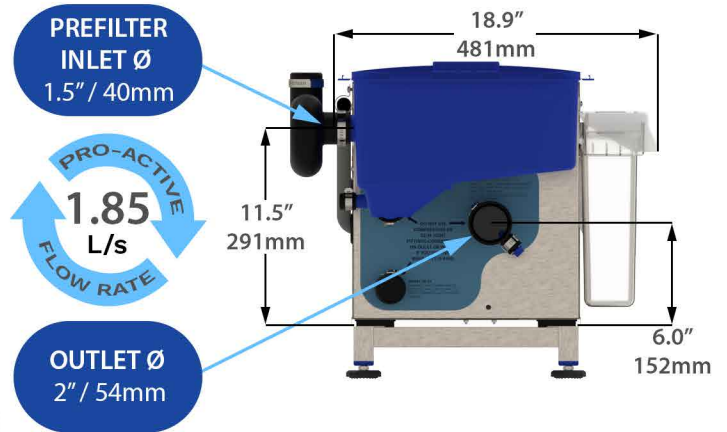
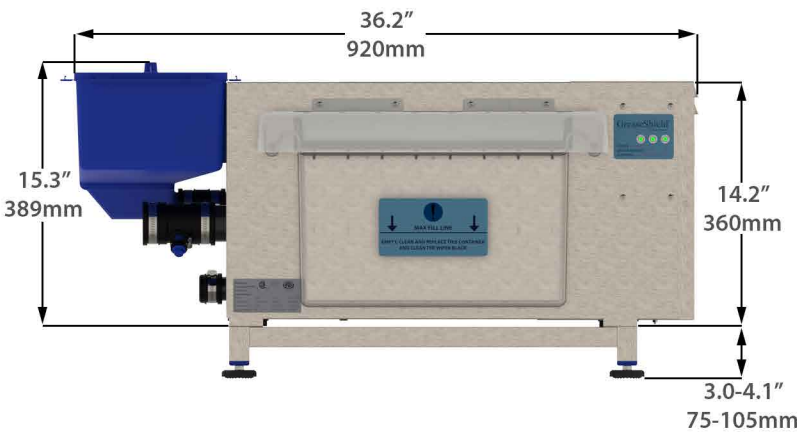

GREASESHIELD® SERVICES

- ✓ Compliance Support & Selection Proposal
- ✓ Site Survey
- ✓ Installation
- ✓ Replacement Parts
- ✓ Nationwide Support
- ✓ Service & Maintenance
- ✓ Technical Support & Design



GREASESHIELD® PROTECTS



Environmental Products and Services Ltd

Award Winning Technology

HEAD OFFICE - +44 (0) 28 3083 3081
15 Shepherd's Way, Carnbane Industrial Estate,
Newry, County Down, N. Ireland, BT35 6EE

GB OFFICE - +44 (0) 161 477 5555
Unit 6 Phoenix Court, Whitehill Industrial Estate, Hammond Avenue
South Reddish, Stockport, Manchester, SK4 1PQ